





























- Funktionen der Taster. / *Functions of the buttons.*

	1x  t < 0,6sec ON	Einschalten der Leuchte <i>Switching on the luminaire</i>
	1x  t < 0,6sec 	Einstellen des direkt/indirekt Anteils <i>Setting the direct/indirect component</i>
	1x  t > 0,6sec 	Dimmen <i>Dimming</i>
	1x  t < 0,6sec OFF	Ausschalten der Leuchte <i>Switching off the luminaire</i>
	1x  t > 0,6sec 	Dimmen <i>Dimming</i>

- Funktionen der opt. Fernbedienung. / *Functions of the optional remote control.*

	1x  ON		Einschalten der Leuchte <i>Switching on the luminaire</i>
	1x  OFF		Ausschalten der Leuchte <i>Switching off the luminaire</i>
	 		Hochdimmen <i>dim up</i>
	 		Runterdimmen <i>dim down</i>

	Atomatikmodus der konstanten Beleuchtungsstärke <i>Automatic mode of constant illumination level</i>		Aktuelle Beleuchtungsstärke einstellen (Taste > 3 s drücken) <i>Save current illumination level (press button > 3 s)</i>
--	---	--	---

Wartungshinweis / *maintenance reference*



Haftungsausschluss / *Disclaimer*

Bei Schäden, die durch Nichtbeachtung der Montageanleitung verursacht werden, erlischt jeglicher Gewährleistungsanspruch. Bei Nichtbeachtung der Hinweise und unsachgemäße Bedienung wird für Folge-, Sach- und Personenschäden keine Haftung übernommen.

In the event of damage caused by failure to follow the mounting instruction, the warranty claims expire. In case of disregard of the instructions and improper handling, we assume no liability for consequential, material and personal damage.

Montageanleitung LED Stehleuchte, direkt/indirekt - MSL

Assembly instruction LED free-standing luminaire, direct/indirect - MSL

**WICHTIG!
*IMPORTANT!***

**VOR GEBRAUCH SORGFÄLTIG LESEN!
*READ CAREFULLY BEFORE USE!***

Allgemeine Hinweise / *General notes*

Leuchten für Standardanwendung in trockener Umgebung. Bewahren Sie diese Montageanleitung für eventuelle Wartungs- oder Demontearbeiten auf, bzw. stellen Sie diese Montageanleitung dem entsprechenden Personal zur Verfügung. Technische Änderungen werden vorbehalten.

Alle Maße in mm.

Luminaire for standard application in dry environment. Keep this assembly instruction safe for maintenance and dismantling or provide it to the adequate staff.

Technical changes are reserved.

Alle Maße in mm.

Sicherheitshinweise / *Safety notes*

1. Die Leuchte darf nur von einer Elektrofachkraft installiert werden.
The Luminaire may be installed only by electrician.
2. Stromzufuhr während der Installation unterbrechen.
Interrupt the power supply during the installation.
3. Niemals defekte Leuchten installieren.
Never install defect luminaire.
4. Arbeiten an der Leuchte nur im spannungsfreien Zustand durchführen (Beachtung der DIN VDE 0100).
Working on the luminaire only in voltage free condition (respect of DIN VDE 0100).

Sonstige Hinweise / *Other notes*

1. Leuchte ist für Innenräume bestimmt (Umgebungstemperatur t_a 25°C).
The luminaire it intended for indoor rooms (ambient temperature t_a 25°C).
2. Chemische Beständigkeit beachten! Nur kunststoffverträgliche Reinigungsmittel verwenden.
Due to problems with chemical resistance, choose cleaning materials, which are suitable for plastic.

Abmessungen / Dimensions

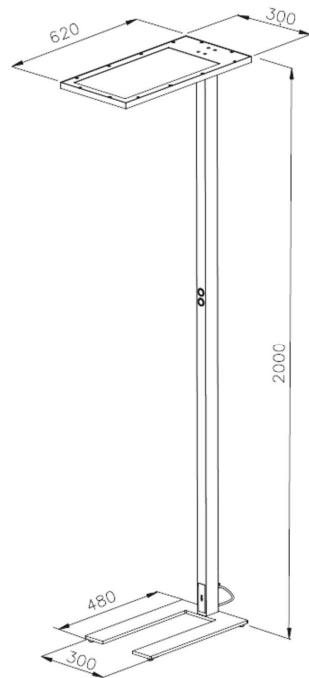

Gewicht / Weight: 10 kg

Technische Daten / Technical Data

Schutzart / Degree of protection

IP20

Schutzklasse / Protection class

SK I

Anschlussspannung / Supply voltage

220-240 V / 50/60 Hz

Zeichen / Signs



RoHS compliant

Mit einer durchgestrichenen Abfalltonne gekennzeichnete Produkte dürfen nicht in den Hausmüll. Für die ordnungsgemäße Entsorgung benutzen Sie bitte die zugelassenen Entsorgungseinrichtungen oder geben Sie die Leuchte an den Händler zurück.
 Products marked with a crossed-out waste bin must not be disposed of with household waste. For proper disposal, please use the approved disposal facilities or return the luminaire to the supplier.

Elektrischer Anschluss und Montage / Electrical connection and assembly

- Montieren des Fußes und Kopfes mittels jeweils 4 Schrauben. / *Mount the foot and head with 4 screws each.*
- Vor der Montage des Kopfes den Steckverbinder verbinden. / *Before mounting the head, connect the connector.*
- Unter den beiden vorderen Schrauben des Kopfes muss jeweils eine Zahnscheibe angebracht werden. / *A lock washer must be fitted under each of the two front screws of the head*

